



900X70 Refractor Telescope Instruction Manual

For products #6001 & #6002

www.iOptron.com

Table of Contents

Table of Contents	2
1. Telescope Assembly	3
1.1. 900X70 Assembly Terms	3
1.2. Telescope Assembly	5
2. Understanding Celestial Motion and Coordinates	7
3. Getting Started	8
3.1. Selecting an Eyepiece.....	8
3.2. Focusing Telescope.....	8
3.3. Aligning Finderscope:.....	8
3.4. Balancing the Telescope	8
3.5. Polar Alignment of the Equatorial mount	9
4. Using the Telescope	10
4.1. Getting familiar with you mount and telescope.....	10
4.2. Star observation	10
4.3. Observation Tips	10
4.4. How to use setting circles.....	10
4.5. Calculating the Power	11
5. Maintenance.....	12
6. Technical Specifications	13
IOPTRON ONE YEAR LIMITED WARRANTY	14

1. Telescope Assembly

1.1. 900X70 Assembly Terms

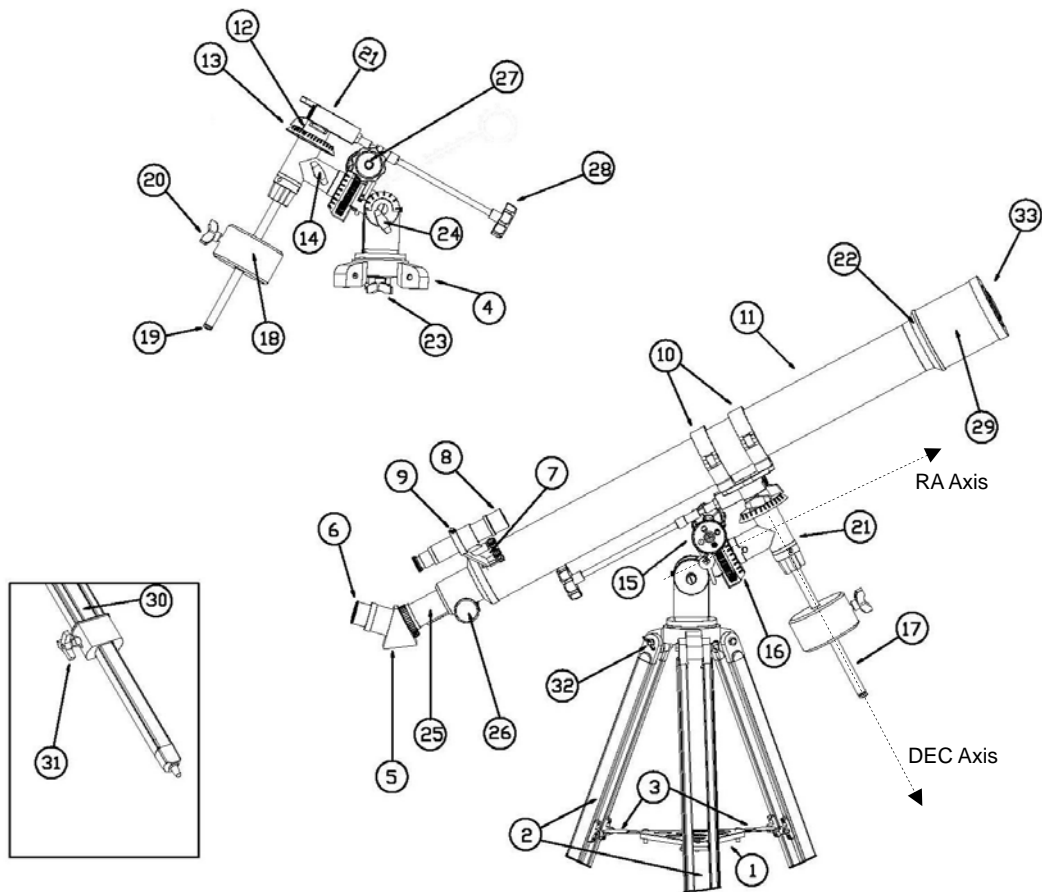
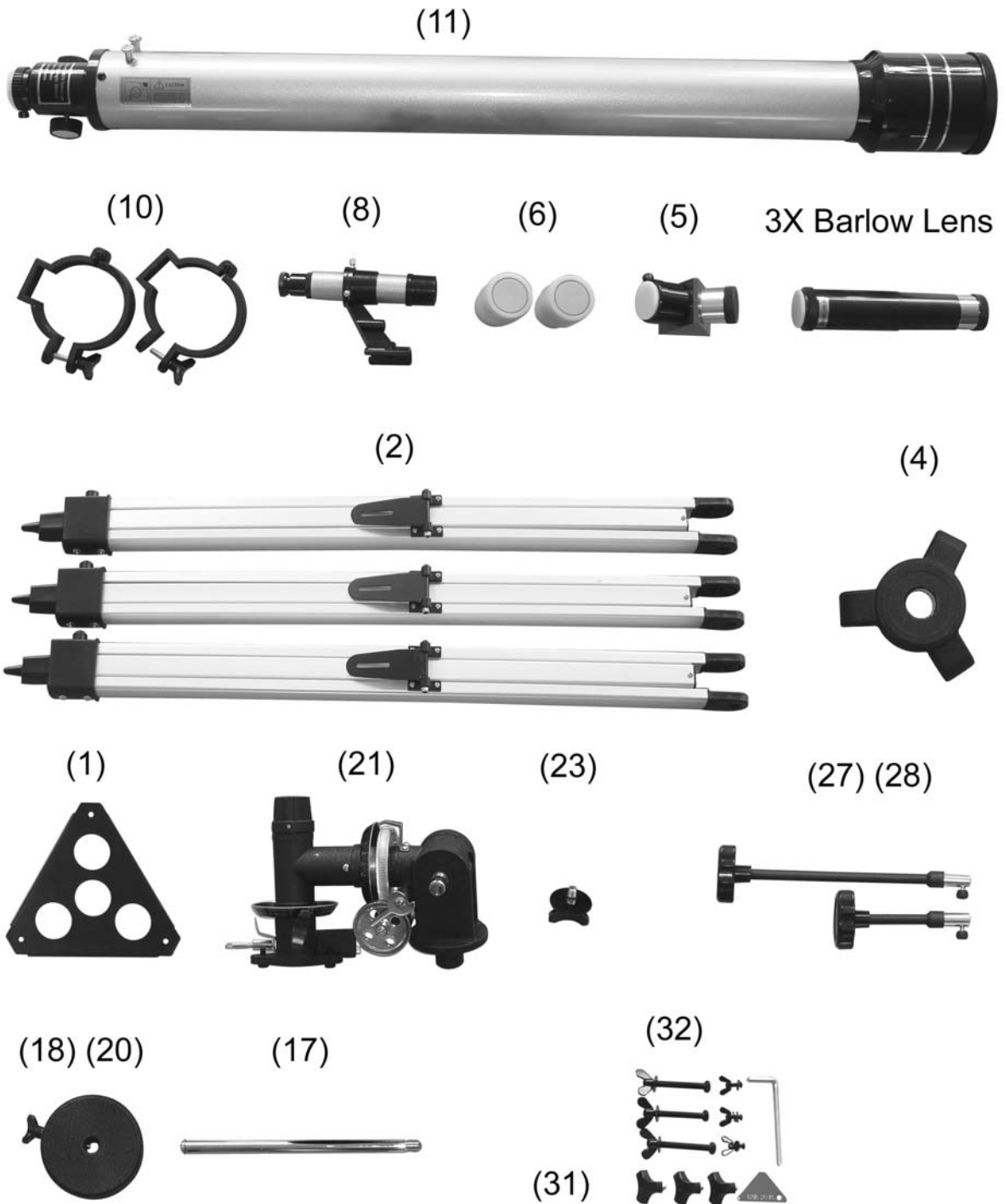

Figure 1. 900X70

- | | |
|--------------------------------------|--|
| (1). Accessory holder tray | (18). Counterweight |
| (2). Aluminum tripod | (19). Counterweight safety washer |
| (3). Leg lock brackets | (20). Counterweight locking knob |
| (4). Tripod base | (21). Equatorial mount head |
| (5). Diagonal mirror | (22). Lens cell |
| (6). Eyepiece | (23). Azimuth adjustment knob |
| (7). Finderscope bracket | (24). Latitude adjustment knob |
| (8). Finderscope | (25). Eyepiece holder tube |
| (9). Finderscope collimation screws | (26). Focusing knob |
| (10). Scope mounting ring | (27). Right ascension control cable |
| (11). Main optical tube | (28). Declination control cable |
| (12). Declination locking knob | (29). Sunshade |
| (13). Declination setting circle | (30). Sliding inner tripod leg extension |
| (14). Right ascension locking knob | (31). Leg extension locking knob |
| (15). Right ascension gear | (32). Tripod leg bolts |
| (16). Right ascension setting circle | (33). Front lens dust cap |
| (17). Counterweight shaft | |

Figure 2. Parts List



1.2. Telescope Assembly

The numbers in brackets refer to the keys shown in Figures 1 & 2.

1. Unpack and identify the components of your telescope using the list shown in previous page.
2. Take the tripod legs (2) out of the package. Make sure the locking knobs (31) are tightened.

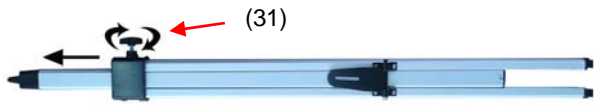

3. Mount three tripod's legs (2) to the tripod base (4) using the three long tripod leg bolts (32) with their washers and wing nuts. Make sure that the three hinged leg lock brackets (3) are facing inside (as shown in figure. 1)

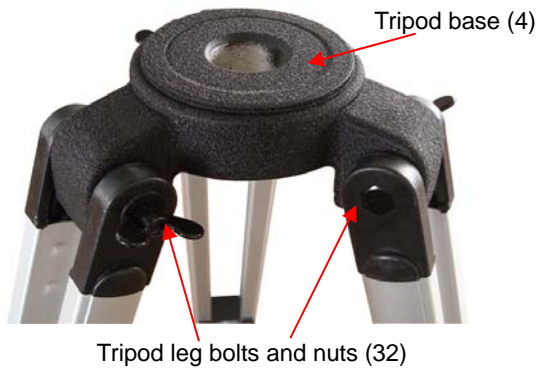

4. Stand the telescope's tripod mount upright by spreading the tripod's legs out uniformly. Attach the accessory holder tray (1) to the leg lock brackets (3) using the short screws and wing nuts supplied.

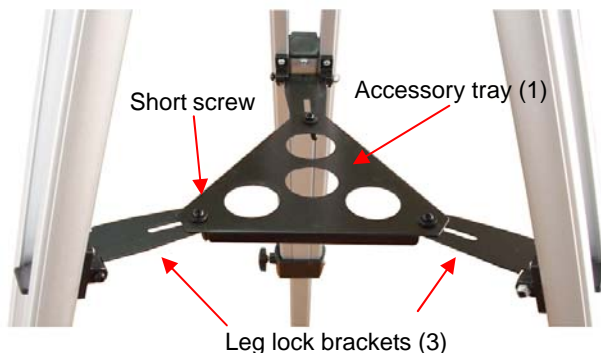

5. Unlock the tripod leg extension locking knob (31). Extend tripod legs to desired height and lock the leg locks afterwards.

6. Insert the base of the equatorial mount head into the hole of the tripod base (4) and secure it using azimuth adjustment knob (23). Make sure the right ascension (R.A.) gear (21) is below the R.A. setting circle (13).

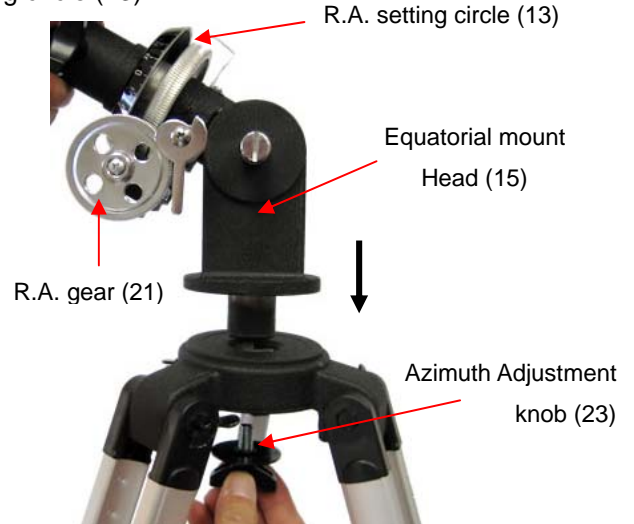

7. Put the optical tube mounting (10) onto the equatorial mount and secure it using 2 supplied hex head screws.



8. Slide counterweight (18) onto the counterweight shaft (17) and secure the counterweight by tightening the counterweight locking knob (20). Screw counterweight shaft (17) onto the base of the declination (Dec) axis on the equatorial mount. Once this shaft is firmly in place, release the locking knob (20), adjust the counterweight up some 50 mm from the end of the shaft and retightening the locking knob (20).

⚠ Counter weight is heavy. Please handle with care to avoid injury!

9. Assemble the right ascension (R.A.) control cable (27, short cable) and declination (Dec) control cable (28). These cables are locked into position by firmly tightening the screws at the end of each cable.

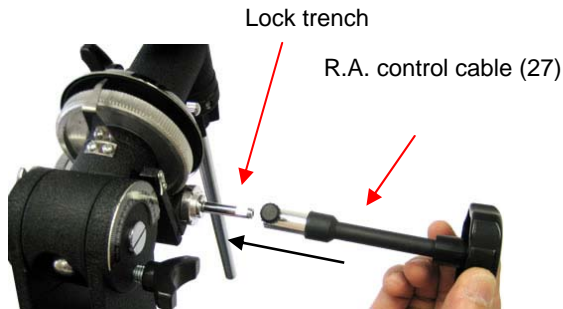

11. Loosen two screws at the end of the OTA. Mount the finderscope bracket (7) onto the telescope using these two knurled screws.

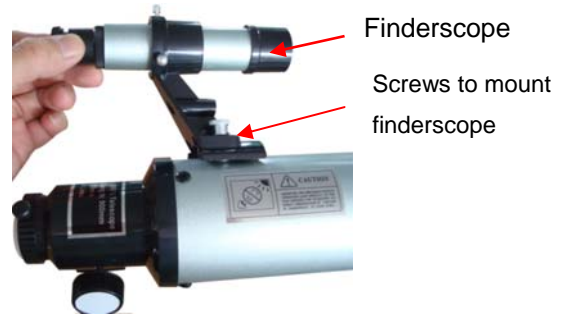

10. Place the optical tube assembly (OTA) (11) into the scope mounting rings (10) and tighten the two wing screws on the tube mounting to secure the OTA.

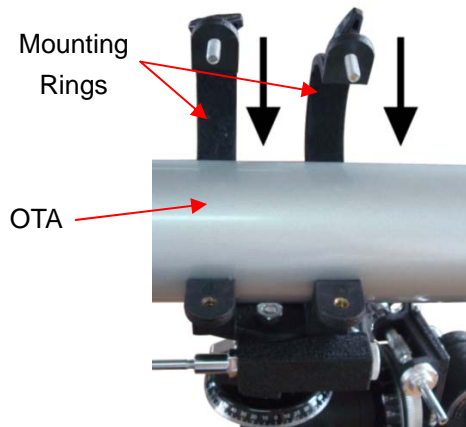

12. Insert the diagonal (5) into the eyepiece holder tube (25) and the eyepiece (6) into the diagonal. Tighten the thumbscrews to a firm feel only. If the 3X Barlow lens is needed, insert the Barlow into the eyepiece holder tube first.

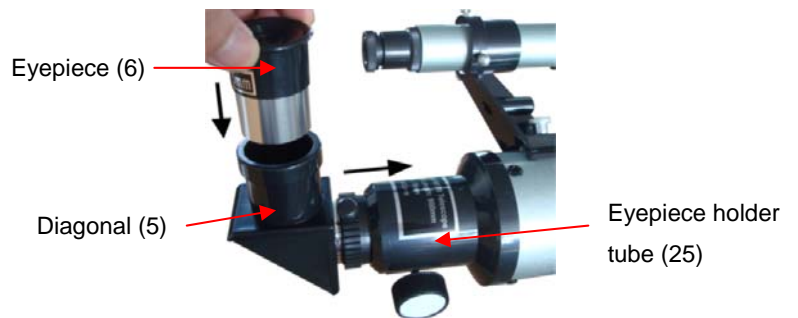

The telescope is now fully assembled and ready to use. You can move the telescope in altitude direction (up and down) and azimuth direction (left or right) by slightly release the latitude adjustment knob (24) and azimuth adjustment knob (23). Or you can move the telescope along the right ascension and declination direction by loosen the right ascension locking knob (14) and declination locking knob (12).

2. Understanding Celestial Motion and Coordinates

Understanding where to locate celestial objects and how these objects move through the sky is fundamental to fully appreciating astronomy as a hobby. Most amateur astronomers use the same visual path (or star-hopping) method for locating celestial objects. To do this they use maps of the sky or an astronomy program that identifies bright stars and constellations of stars that serve as "roadmaps" and "markers" in the sky. These visual reference points guide amateur astronomers in their search for astronomic objects and although the visual path method is the preferred approach—giving thought to whether or not to use circles of digital coordinates for locating objects is desirable as your telescope offers this function. Be warned however, when compared with a visual path approach, looking for objects using circles of digital coordinates requires a greater investment in terms of patience and time in order to achieve a more precise alignment of the telescope's polar axis on the celestial pole. This is partially why the visual path approach is preferred since it's the simplest (and quickest) way to get started.

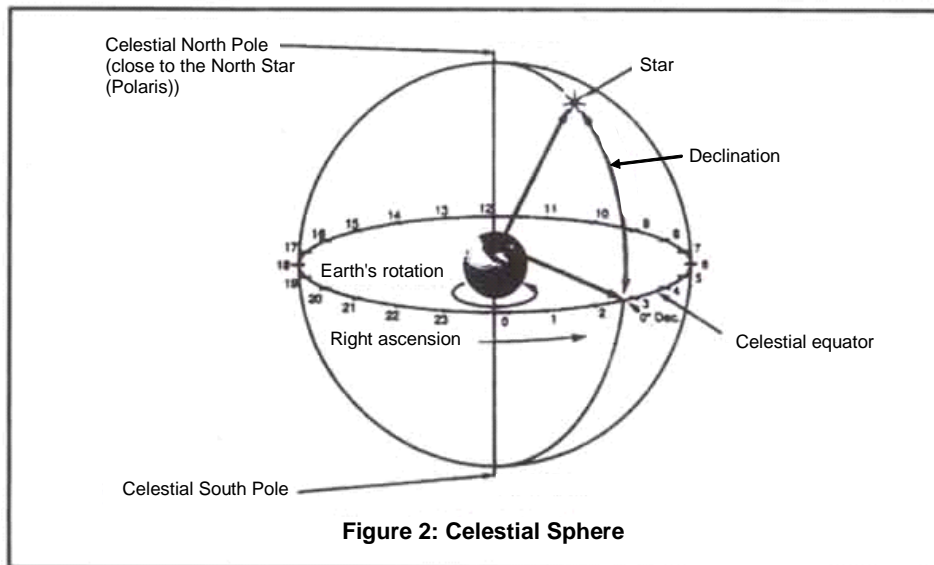

Understanding how astronomic objects move

Given the earth's rotation, () bodies (stars) appear to move from east to west along a curved trajectory across the sky. The trajectory that they follow is known as the right ascension line (R.A.). The angle of the trajectory that they follow is known as the declination line (Dec.). The right ascension and the declination form a system that is similar to

the terrestrial system of latitude and longitude.

In the system of R.A. and Dec. coordinates, stars are projected onto the "celestial sphere", i.e. onto the imaginary sphere where all of the stars appear to be located.

Understanding celestial coordinates

In the system of celestial coordinates, the poles are defined as being the two points where the earth's rotation axis, when prolonged infinitely to the north and to the south, intersects with the celestial sphere. Consequently, the celestial North Pole is the point in the sky where the prolongation of the earth's axis passing through the North Pole intersects the celestial sphere. In fact this point in the sky is located close to the North Star or pole star (Polaris).

So-called "longitude lines" are drawn on the earth's surface between the north and south poles. In the same way, "latitude lines" are drawn along an east-west direction, parallel to the earth's equator. The celestial equator is simply a projection of the earth's equator into the celestial sphere. Just like on the earth's surface, imaginary lines have been

drawn on the celestial sphere to form a grid of coordinates. The positions of the stars on the earth's surface are specified by their latitude and longitude.

The celestial equivalent to terrestrial latitude is called "Declination" or simply "Dec", expressed in degrees, minutes, and seconds north ("+") or south ("-") of the celestial equator. Consequently any point located along the celestial equator (e.g.

passing through the constellations of Orion, Virgo and Aquarius) is specified by its declination of $0^{\circ}0'0''$. The declination of the North Star or pole star located very close to the North Celestial Pole is $+89.2^{\circ}$.

The celestial equivalent to terrestrial longitude is called "Right Ascension" or "R.A.", expressed in hours, minutes and seconds from a "zero" R.A. line defined arbitrarily and which passes through the

constellation of Pegasus. The coordinates of the Right Ascension range from 0h 0m 0s to 24h 0m 0s (not inclusive). Therefore, there are 24 primary R.A. lines located at 15 degree intervals along the celestial equator. The objects that are further away, eastwards, from the primary Right Ascension grid line (0h 0m 0s) carry rising R.A. coordinates.

Consequently, once it is possible to specify the position of all of these celestial objects using their Right Ascension and Declination coordinates the task of searching for objects (especially low brightness stars) using the astronomer's telescope may be simplified. The digital, R.A. (16) and Dec. (13) setting circles for your telescope can be made up, in practice to read the object's coordinates, by positioning it close to the telescope's telescopic field of view (FOV). The advantage of using these setting circles is however only justified after first correctly aligning the telescope with the North Celestial Pole.

3. Getting Started

Before you can use the telescope effectively, there are still a few steps to be performed.

3.1. Selecting an Eyepiece

1. Always begin viewing with the lowest power eyepiece. (Note: a 20 mm focal length eyepiece is lower power than a 12.5 mm one.) A formula can be used to determine the power of each eyepiece: Telescope focal length divided by eyepiece focal length equals magnification. Ex. $900\text{mm} \div 20\text{mm} = 45\text{X}$ (magnification)

2. Included with this telescope is a 45° Erecting Diagonal Prism. The Erecting Diagonal Prism is used to erect the image you will see. Astronomical telescopes are designed in such a way that the image you see may be UPSIDE DOWN and REVERSED. This is acceptable for viewing celestial bodies.

3.2. Focusing Telescope

1. After selecting the desired eyepiece aim the main telescope tube at a land-based target at least 200 yards away (e.g. A telephone pole or a building). Fully extend focusing tube by turning the focus knob.

2. While looking through selected eyepiece, slowly retract focusing tube by turning focusing knob until object comes into focus.

3.3. Aligning Finderscope:

The extended field of vision offered by the 5x24 mm finderscope (8) makes it easier to aim at an object before viewing it through the main telescope tube with a higher magnification.

1). Remove the front lens cover (33) from the sunshade (29). Look through Main Telescope Tube and establish a well-defined target (see focusing telescope section). Tighten all lock knobs (Declination, Latitude, Right Ascension, Horizontal Axis) so that telescope's aim is not disturbed.

2). Looking through the finderscope, alternate tightening or loosening each finderscope Adjustment Screw (9) until the crosshairs of the finderscope are precisely centered on the same object already centered in Main Telescope Tube's field of view.

3). Now, objects located with the finderscope first will be centered in FOV of the main telescope. They can be focused by turning the finderscope's threaded eyepiece. The image in the finderscope will be reversed.

3.4. Balancing the Telescope

To insure smooth movement of the telescope on both axes of the equatorial mount, it is imperative that the optical tube be properly balanced. We will first balance the telescope with respect to the right ascension (R.A.) axis and then in the declination (Dec.) axis.

1. Keeping one hand on the telescope optical tube (11), loosen the R.A. lock knob (14). Make sure the Dec. lock knob (12) is locked. The telescope should now be able to rotate freely about the R.A. axis. Rotate it until the counterweight shaft (17) is parallel to the ground (i.e., horizontal).

2. Now loosen the counterweight lock knob (20) and slide the weight along the shaft until it exactly counterbalances the telescope. That's the point at which the shaft remains horizontal even when you let go of the telescope with both hands.

3. Retighten the counterweight lock knob. The telescope is now balanced on the R.A. axis.

4. To balance the telescope on the Dec. axis, first tighten the R.A. lock knob (14), with the counterweight shaft (17) still in the horizontal position.

5. With one hand on the telescope optical tube (11),

loosen the Dec. lock knob (12). The telescope should now be able to move freely on the Dec. axis. Loosen the ring clamps on the tube rings (10) a few turns, until you can slide the telescope tube forward and back inside the rings (this can be aided by using a slight twisting motion on the optical tube while you push or pull on it).

6. Position the telescope in the tube rings (10) so it remains horizontal when you carefully let go with both hands. This is the balance point for the optical tube (11) with respect to the Dec. axis.

7. Retighten the ring clamps.

3.5. Polar Alignment of the Equatorial mount

Objects located in the sky appear to revolve around the celestial pole. In northern latitudes, the North Star (Polaris) is close to the pole. (In actual fact, stars are essentially "fixed" in place and their apparent motion is caused by the earth rotating around its own axis.) Over a 24 hour period, stars will perform a complete revolution around the pole, generating concentric circles with the pole at their center. By aligning the telescope's polar axis with the celestial north pole (or with the celestial south pole for observers located in the earth's southern hemisphere), astronomic objects may be followed (or tracked) by simply moving the telescope around an axis, the polar axis.

If the telescope is reasonably aligned with the pole, changing the instrument's declination using its flexible control cable will consequently be of little use – almost all the telescope motion required will take place using the Right Ascension coordinates. (If the telescope is perfectly aligned with the pole—no declination change will be required to follow stellar objects). For occasional visual observations through the telescope, aligning the telescope's polar axis by one or two degrees in relation to the pole is more than enough. With this level of aiming precision the telescope can achieve precise tracking if the R.A. flexible control cable is used while maintaining the objects within the telescope's FOV for some 20 to 30 minutes.

To polar-align the telescope:

1. Level the equatorial mount by adjusting the length of the three tripod legs (2).

2. Loosen the latitude adjustment knob (24) and tilt the mount until the pointer on the latitude scale is set at the latitude of your observing site. If you don't know your latitude, consult a geographical atlas or

search the internet. For example, if your latitude is 35° north, set the pointer to 35. Then retighten the latitude knob. The latitude setting should not have to be adjusted again unless you move to a different viewing location some distance away.

3. Loosen the Dec. lock knob (12) and rotate the telescope optical tube (11) until it is parallel with the R.A. axis, as it is in Figure 1. The pointer on the Dec. setting circle (13) should read 90°. Retighten the Dec. lock knob.

4. Loosen the azimuth adjustment knob (23) on the mount and rotate the mount so the telescope tube (and R.A. axis) points roughly at Polaris. If you cannot see Polaris directly from your observing site, consult a compass and rotate the mount so the telescope points north. Retighten the azimuth adjustment knob.

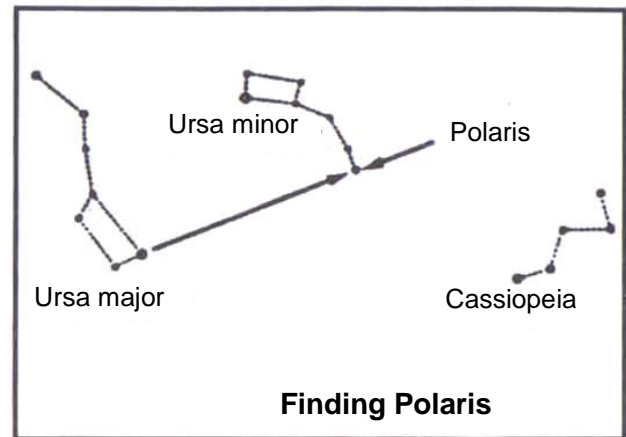

The equatorial mount is now polar aligned.

From this point on in your observing session, you should not make any further adjustments in the azimuth or the latitude of the mount, nor should you move the tripod. Doing so will undo the polar alignment. The telescope should be moved only about its R.A. and Dec. axes.

4. Using the Telescope

With the telescope aligned on the pole, you are now ready to start your observations.

4.1. Getting familiar with you mount and telescope

Before observing a celestial object, looking at terrestrial objects during the day provides a good exercise on how to operate the mount and telescope.

4.2. Star observation

First of all you will need to choose an object that is easy to find. The Moon or a bright star is a good target to start with.

1. Slightly loose the telescope's Right Ascension locking knob (14) and the Declination locking knob (12), located close to the Declination adjustment ring (13). By applying slight pressure by hand, the telescope should now move freely along its two axes.

2. Move the telescope along R.A. and Dec axes and using the aligned finderscope to find the Moon. With the object centered in the finderscope's cross hairs, retighten the R.A. and Dec. knobs.

3. The Moon should be visible somewhere within the FOV of main telescope. Focus the image by adjusting the focusing knob (26). Center the Moon by adjusting the mount using RA and DEC control cable (27, 28).

4. You'll find that the object immediately starts to shift across the FOV. This motion is due to the earth rotation. To "track" the object and keep it in the FOV, turn the cable that controls R.A. slow motion (27). Objects will appear to move faster at higher magnifications. The Declination control cable (28) is only used for centering the object and not for tracking.

4.3. Observation Tips

When selecting a location for observing, get as far away as possible from direct artificial light such as street lights, porch lights, and automobile headlights. The glare from these lights will greatly impair your dark-adapted night vision. Set up on a grass or dirt surface, not asphalt, because asphalt radiates more heat, which disturbs the surrounding

air and degrades the images seen through the telescope. Avoid viewing over rooftops and chimneys, as they often have warm air currents rising from them. Avoid observing from indoors through an open (or closed) window, because the temperature difference between the indoor and outdoor air will cause image blurring and distortion. Furthermore, it is preferable to let your telescope reach outside ambient (surrounding) temperature before starting an observation cycle.

Wait a few minutes to allow your eyes to become used to the darkness before attempting any serious observations. Use a flashlight with a red filter to preserve your night vision when looking at star maps or checking telescope parts.

Avoid touching the eyepiece during observation. Vibration generated by this contact may cause the view to move. Also avoid observing from locations where terrestrial vibrations are significant. Observing from the upper floors of buildings may also cause the images vibrating.

Warning! Never attempt to observe the sun through your telescope without a proper solar filter. Observing the sun, even for a fraction of a second, may cause immediate and irreversible harm to your eye as well as physical damage to the telescope.

Some atmospheres may deform the image that you are observing. Planets in particular, when observed low on the horizon, often present a fuzziness – the same object when observed at a higher altitude in the sky may benefit from far better definition and a far higher degree of contrast. Furthermore, air turbulence in the upper layers of the atmosphere may cause "trembling" to affect the view observed through the eyepiece. In this case, reduce the magnification factor until the picture stabilizes. Keep in mind that even a small sized but bright and well defined image will reveal far more interesting details than a larger, but less bright and slightly fuzzy, view.

4.4. How to use setting circles

Understanding the Setting Circles

The setting circles on an equatorial mount enable you to locate celestial objects by their "celestial coordinates". The R.A. and Dec. values for celestial objects can be found in any star atlas or star catalog.



The mount's R.A. setting circle (16) is scaled in hours, from 1 through 24, with small marks in between representing 6-minute increments. The numbers closest to the R.A. axis gear apply to viewing in the Southern Hemisphere, while the numbers above them apply to viewing in the Northern Hemisphere.

The Dec. setting circle (13) is scaled in degrees, with each mark representing 2° increments. Values of Dec. coordinates range from +90° to -90°. The 0° mark indicates the celestial equator. When the telescope is pointed north of the celestial equator, values of the Dec. setting circle are positive, while when the telescope is pointed south of the celestial equator, values of the Dec. setting circle are negative.

Before you can use the setting circles to locate objects, the mount must be correctly polar aligned, and the R.A. setting circle must be calibrated. The Dec. setting circle has been permanently calibrated at the factory, and should read 90° whenever the telescope optical tube is parallel with the R.A. axis.

Calibrating the Right Ascension Setting Circle

1. Identify a bright star in the sky near the celestial equator (Dec. = 0°) and look up its coordinates in a star atlas.
2. Loosen the R.A. and Dec. lock knobs (14, 12) on the equatorial mount, so the telescope optical tube can move freely.
3. Point the telescope at the bright star whose coordinates you know. Lock the R.A. and Dec. lock knobs. Center the star in the telescope's field of view with the R.A. and Dec control cables.
4. Rotate the setting circle until the metal arrow indicates the R.A. coordinate listed in the star atlas

for the object

Finding Objects With the Setting Circles

Now that both setting circles are calibrated, look up a star atlas the coordinates of an object you wish to view. Loosen the Dec. lock knob (12) and rotate the telescope until the Dec. value from the star atlas matches the reading on the Dec. setting circle (13). Remember that values of the Dec. setting circle are positive when the telescope is pointing north of the celestial equator (Dec. = 0°), and negative when the telescope is pointing south of the celestial equator. Retighten the lock knob.

Loosen the R.A. lock knob (14) and rotate the telescope until the R.A. value from the star atlas matches the reading on the R.A. setting circle (16). Remember to use the upper set of numbers on the R.A. setting circle. Retighten the lock knob.

Most setting circles are not accurate enough to put an object dead-center in the telescope's eyepiece, but they should place the object somewhere within the field of view of the finderscope, assuming the equatorial mount is accurately polar aligned. Use the R.A. and Dec control cables to center the object in the finderscope, and it should appear in the telescope's field of view.

The R.A. setting circle must be re-calibrated every time you wish to locate a new object. Do so by calibrating the setting circle for the centered object before moving on to the next one.

4.5. Calculating the Power

The power or magnification offered by a telescope is determined by two factors: the optical or focal length of the telescope's lens and the eyepiece's focal length. This telescope's focal length is 900 mm. To calculate the magnification factor, divide the lens' focal length by that of the eyepiece. The resulting value represents the magnification factor offered by the telescope when it is used with this eyepiece. For example, using a 20 mm eyepiece provides a magnification factor of:

$$\text{Magnification} = 900 \text{ mm} / 20 \text{ mm} = \mathbf{45X}$$

A Barlow lens is used to increase the magnification of each eyepiece. First insert the Barlow 3X lens in the telescope's eyepiece holder, then the eyepiece itself. Secure the lens using thumb nail screws. The total magnification will be 135X when a 20 mm eyepiece (45X) and a 3X Barlow lens are used together.

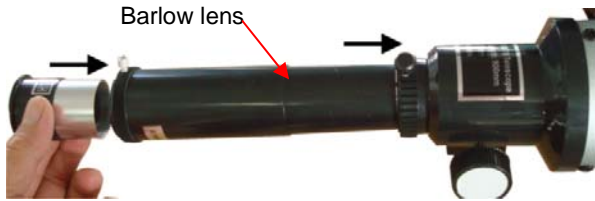

Some words of caution on magnification. Although the theoretical power or magnification of a telescope is virtually limitless, there are practical limits, such as the earth's atmosphere. Every telescope has a useful magnification limit of about 2X per millimeter of aperture. This comes to 140X for the 900X70. Moderate magnifications are what give the best views. It is better to view a small, but bright and detailed image than a dim, unclear, oversized image.

5. Maintenance

If you give your telescope reasonable care, it will last a lifetime. Store it in a clean, dry, dust free place, safe from rapid changes in temperature and humidity. Do not store the telescope outdoors,

although storage in a garage or shed is OK. Small components like eyepieces and other accessories should be kept in a protective box or storage case. Keep the caps on the front of the telescope and on the focuser drawtube when not in use.

Your 900X70 telescope requires very little mechanical maintenance. The optical tube is aluminum and has a smooth painted finish that is fairly scratch resistant. If a scratch does appear, it will not harm the telescope.

Cleaning Lenses

Any quality optical lens cleaning tissue and optical lens cleaning fluid specifically designed for multi-coated optics can be used to clean the objective lens and the exposed lenses of your eyepieces. Never use regular glass cleaner or cleaning fluid designed for eyeglasses.

Before cleaning with fluid and tissue, blow any loose particles off the lens with a blower bulb or compressed air. Then apply some cleaning fluid to a tissue, never directly on the optics. Wipe the lens gently in a circular motion, then remove any excess fluid with a fresh lens tissue. Oily fingerprints and smudges may be removed using this method. Use caution— rubbing too hard may scratch the lens. For the larger surface of the objective lens, clean only a small area at a time, using a fresh lens tissue on each area. Never reuse tissues.

6. Technical Specifications

Optical tube	Aluminum
Optical Design	Achromatic Refractor
Objective lens	Air-spaced, fully coated
Clear Aperture	70 mm
Focal Length	900mm
Focal Ratio	f/12.8
Focuser	Rack and pinion, accepts 1.25" eyepieces and accessories
Eyepiece	H12.5mm, H20mm
diagonal	45° Erecting Prism, 1.25"
Magnification with supplied eyepiece	45X (w/ 20mm), 72X (w/12.5mm)
Barlow Lens	3X
Finding Scope	5X24
Mount	EQ-2, German equatorial
Tripod	Aluminum
Motor drive	Optional
Total Weight	20 lbs.

IOPTRON ONE YEAR LIMITED WARRANTY

A. iOptron warrants your telescope, mount, or controller to be free from defects in materials and workmanship for one year. iOptron will repair or replace such product or part which, upon inspection by iOptron, is found to be defective in materials or workmanship. As a condition to the obligation of iOptron to repair or replace such product, the product must be returned to iOptron together with proof-of-purchase satisfactory to iOptron.

B. The Proper Return Authorization Number must be obtained from iOptron in advance of return. Call iOptron at 1.866.399.4587 to receive the number to be displayed on the outside of your shipping container.

All returns must be accompanied by a written statement stating the name, address, and daytime telephone number of the owner, together with a brief description of any claimed defects. Parts or product for which replacement is made shall become the property of iOptron.

The customer shall be responsible for all costs of transportation and insurance, both to and from the factory of iOptron, and shall be required to prepay such costs.

iOptron shall use reasonable efforts to repair or replace any telescope, mount, or controller covered by this warranty within thirty days of receipt. In the event repair or replacement shall require more than thirty days, iOptron shall notify the customer accordingly. iOptron reserves the right to replace any product which has been discontinued from its product line with a new product of comparable value and function.

This warranty shall be void and of no force or effect in the event a covered product has been modified in design or function, or subjected to abuse, misuse, mishandling or unauthorized repair. Further, product malfunction or deterioration due to normal wear is not covered by this warranty.

IOPTRON DISCLAIMS ANY WARRANTIES, EXPRESS OR IMPLIED, WHETHER OF MERCHANTABILITY OF FITNESS FOR A PARTICULAR USE, EXCEPT AS EXPRESSLY SET FORTH HERE. THE SOLE OBLIGATION OF IOPTRON UNDER THIS LIMITED WARRANTY SHALL BE TO REPAIR OR REPLACE THE COVERED PRODUCT, IN ACCORDANCE WITH THE TERMS SET FORTH HERE. IOPTRON EXPRESSLY DISCLAIMS ANY LOST PROFITS, GENERAL, SPECIAL, INDIRECT OR CONSEQUENTIAL DAMAGES WHICH MAY RESULT FROM BREACH OF ANY WARRANTY, OR ARISING OUT OF THE USE OR INABILITY TO USE ANY IOPTRON PRODUCT. ANY WARRANTIES WHICH ARE IMPLIED AND WHICH CANNOT BE DISCLAIMED SHALL BE LIMITED IN DURATION TO A TERM OF TWO YEARS FROM THE DATE OF ORIGINAL RETAIL PURCHASE.

Some states do not allow the exclusion or limitation of incidental or consequential damages or limitation on how long an implied warranty lasts, so the above limitations and exclusions may not apply to you.

This warranty gives you specific legal rights, and you may also have other rights which vary from state to state.

iOptron reserves the right to modify or discontinue, without prior notice to you, any model or style telescope.

If warranty problems arise, or if you need assistance in using your telescope, mount, or controller contact:

iOptron Corporation
Customer Service Department
6F Gill Street
Woburn, MA 01801
www.ioptron.com
Tel. (866)399-4597 (Toll Free in US)
Tel: +1 781.569.0200
Fax: +1 781.935.2860
Monday-Friday 9AM-5PM EST

NOTE: This warranty is valid to U.S.A. and Canadian customers who have purchased this product from an authorized iOptron dealer in the U.S.A. or Canada or directly from iOptron. Warranty outside the U.S.A. and Canada is valid only to customers who purchased from an iOptron Distributor or Authorized iOptron Dealer in the specific country. Please contact them for any warranty services.